

M Series

Audience events
Auditoriums
Boardrooms
Broadcast studios
Conference rooms
Home cinema
Houses of worship
Post-production
Training rooms
And more...



Redefine your expectations.



We didn't just raise the bar. We redefined the entire game.

THE CHRISTIE M SERIES JUST GOT WIDER.

We've designed the M Series, a flexible, efficient line of 3-chip DLP® projectors, with your needs in mind. We've thought of it all, put it into a sleek, compact chassis and provided you with a full set of options.

The most compact in its class, this dual mercury lamp platform provides the high-performance and feature-rich standards you've come to expect from all Christie products. You'll see that we continue to deliver brightness, versatility, reliability, affordability and now, native wide resolution in the most recent additions to the Christie family of display solutions.

Ranging from 2850 ANSI lumens/3135 center lumens (single lamp, 200W) to 10,500 ANSI lumens/11,550 center lumens (dual lamp, 350W), each of the M Series projectors offer high efficiency and low cost of ownership by operating at 1320W – giving you full brightness while

using less power. These projectors employ feedback systems to determine the number of lamps and power level used to adjust the fan speed required to cool the system.

The Christie M Series platform now includes four resolutions, WXGA (1366 x 768), SX+ (1400 x 1050), HD (1920 x 1080) and WUXGA (1920 x 1200), all with a variable contrast ratio of 2500-10,000:1* (full on/full off)/650:1 ANSI for crisp, detailed images. Each of the projectors in the series can also be fitted with the broadest range of high-quality lenses – all with true Intelligent Lens System (ILS™) capabilities.

All this, combined with a 3-year warranty and our industry-leading service and support, enables the M Series to provide high performance and peace of mind for all users.

* Using dynamic iris.

CHRISTIE®

[1] Dual-lamp system^{1,2}

High-efficiency, dual-lamp system:

- 200W or 350W (two lamp system)
- 120V (operation) for full brightness
- At maximum brightness 10,500 ANSI lumens (11,500 center lumens) the unit only draws 1320W
- Stand by power consumption (phantom power draw) is less than 20W
- Lamps can be hot swapped while projector is powered on and in use

Brightness		200W	350W
Dual lamp	max power	6300 ANSI lumens (6930 center lumens)	10,500 ANSI lumens (11,500 center lumens)
	min power	4725 ANSI lumens (5200 center lumens)	8535 ANSI lumens (9400 center lumens)
Single lamp	max power	3150 ANSI lumens (3465 center lumens)	5250 ANSI lumens (5775 center lumens)
	min power	2360 ANSI lumens (2600 center lumens)	4260 ANSI lumens (4700 center lumens)

Lumen values in table above are for SX+ models.
Flexible lumens levels at various lamp powers.
Lamp power is specific to each model and cannot be interchanged.

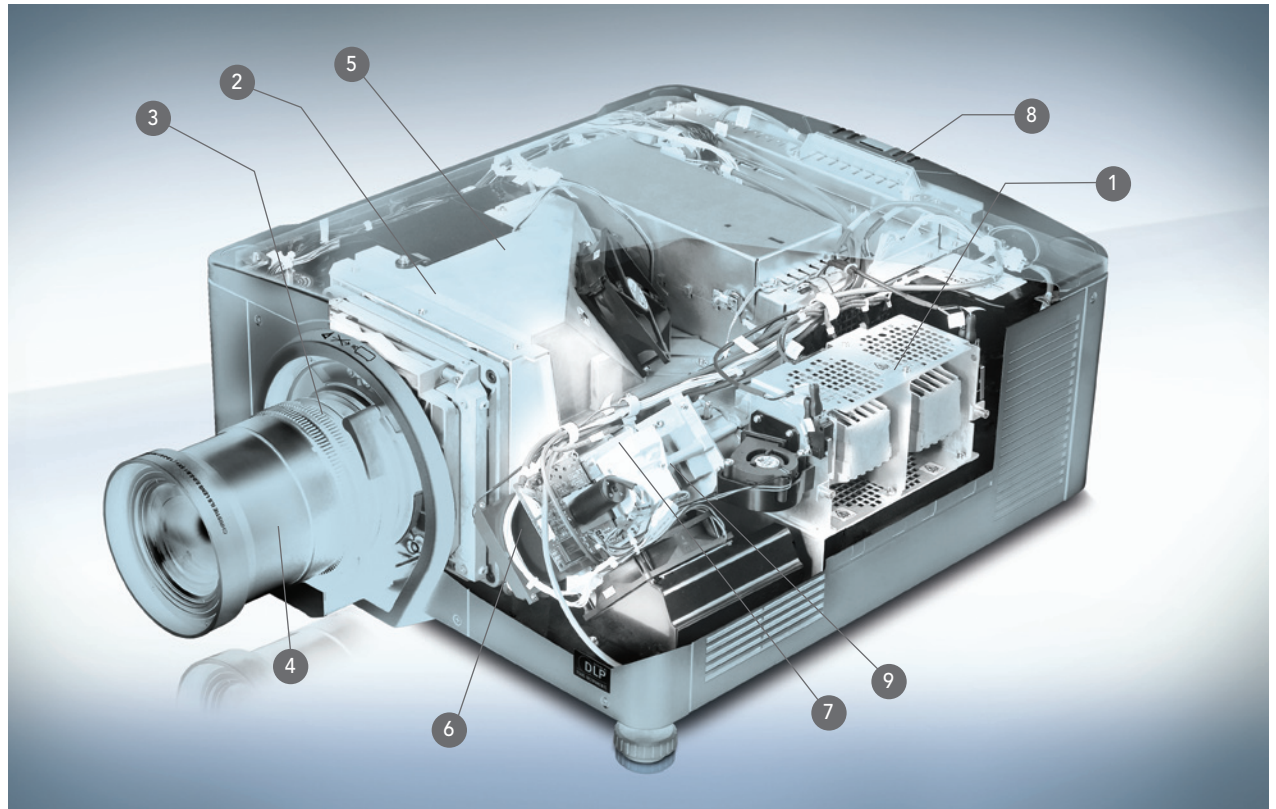

[2] Image quality

3-chip DLP® technology, high-quality optics and world-class 10-bit image processing.

With low maintenance and highly reliable (>100,000 hours) DLP® technology, the Christie M Series delivers:

- High brightness
- Excellent color
- Excellent uniformity
- High contrast
- Excellent fill ratio

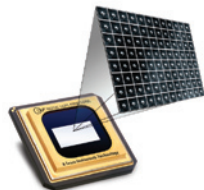

[3] Intelligent Lens System (ILS™)



The ILS automatically recognizes and calibrates a lens when it is installed. Stepper motor based encoding ensures that motor drift does not occur, as typically found with DC encoded motors, providing accurate and repeatable recall of all lens offset, zoom and focus positions.

[4] Expanded lens suite



With the addition of a short zoom (1.25-1.6:1 SX+/ 1.16-1.49:1 HD) and a long zoom (7.5-11.2:1 SX+/ 6.9-10.4:1 HD), this expanded suite provides the broadest range of HD lenses in this marketplace.

[5] Dust sealed engine

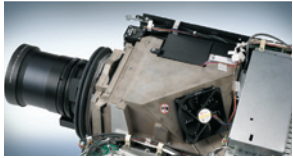

M Series projectors can operate filter-free because of dust-sealed engines and optics. Since dust and dirt cannot affect the system and filters are not required, image quality is maintained and maintenance costs are lower. Removable side panels enable the addition of optional coarse dust and fog juice filters for projectors that are exposed to harsh environments.

[6] Motorized yellow notch filter²

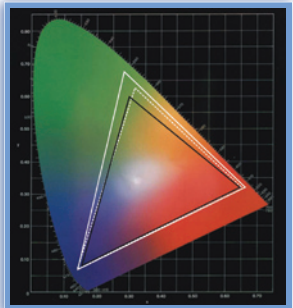

- Expanded color gamut
- Regular color gamut
- REC 709

The motorized yellow notch filter optically expands the color gamut for richer greens and yellows. Since you lose some brightness by improving the greens and yellows, this is a channel-configurable option which enables you to decide when it is needed. This filter, available on M Series HD models only, is ideal when video is being displayed.



Standard color gamut



Expanded color gamut

[7] Dynamic iris

Ideal for video applications, the dynamic iris is a channel-configurable option. It automatically adjusts an internal iris to extend the range of blacks and provide richer details during dark scenes for true image reproduction.

A variable contrast ratio of 2500-10,000:1 produces a picture with a rich, dynamic appearance.

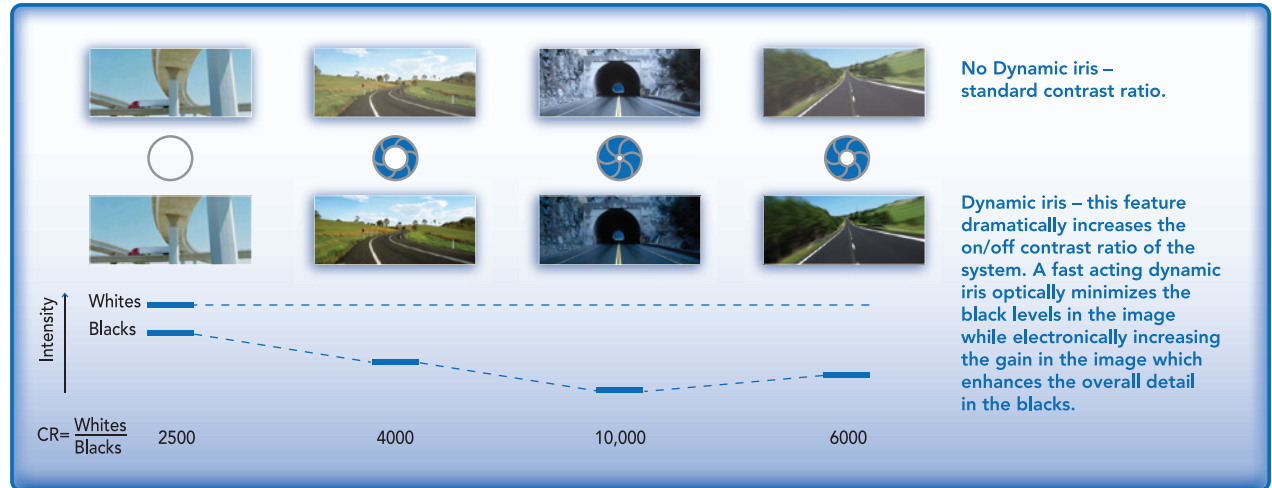

[8] Embedded Christie Twist™

Standard in all M Series models, Christie Twist™ enables seamless white and black level edge-blending of multiple curved images, faster and more easily than through traditional, manual methods. Controlled by an easy-to-use GUI users can expertly control and edge blend or stack multiple curved images. As well, images can be warped to fit virtually any dimension or shape display. Embedded Christie Twist™ ensures that all M Series projectors work with value-added accessories, such as Christie AutoStack™.

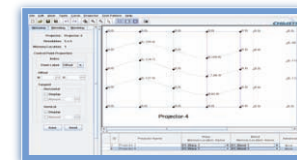

Easy-to-use GUI



Easy-to-use GUI

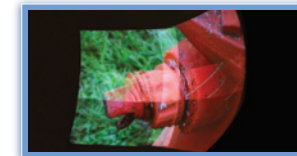

Image on curved screen – before blending



Curved screen – after blending

[9] LiteLOC™¹

The LiteLOC™ feature automatically manages your display's brightness levels over time so that you can match the brightness of a multiple projector system in tiled or blended arrays. This feedback system continuously monitors lamp brightness, so that as the lamp goes through its natural brightness decay, the system increases the lamp power in order to maintain consistent brightness.



No LiteLOC™

LiteLOC™

Wide screen ratios provide a multitude of benefits in a variety of different projection applications. Carefully matching the pixel format of the projector with that of the sources to be displayed will ensure the best image quality and maximum impact. The M Series now offers 4:3, 16:9 and 16:10 models to match the aspect ratio requirements of any application.



WUXGA HD SXGA+ WXGA

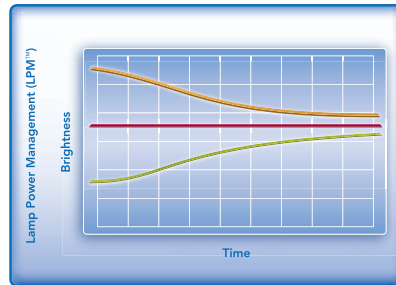
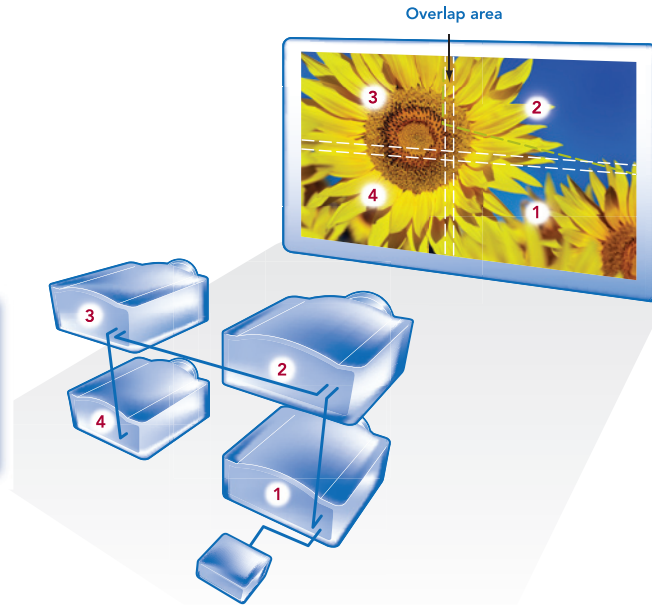

■ Natural lamp brightness ■ Constant regulated brightness ■ Lamp power

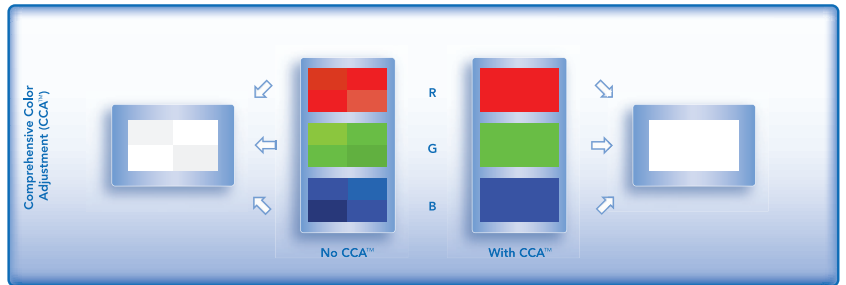

[8] Multi-window/screen processing

External processors are not required for simple, small tiled and blended arrays, therefore lowering your costs for installation. Each M Series projector has the ability to send signals to multiple projectors (up to a 3 x 3 array)* without any additional hardware or software. The projectors in the tiled array can then show only the portion of the signal that they need to project.

[8] Embedded edge blending and color matching

Advanced blending capabilities and Comprehensive Color Adjustment (CCA™) ensure digitally accurate color matching and uniformity across multi-screen blended or tiled images.

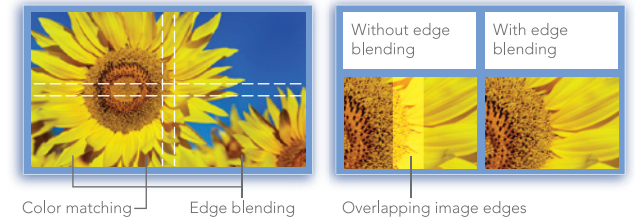

* Subject to input bandwidth limitations.

[8] ChristieNET™ web interface

ChristieNET™ enables users to access all projector menus and controls through a web interface without disrupting the live presentation. This allows for real-time adjustments and monitoring of each projector on the network – regardless of geographic location.

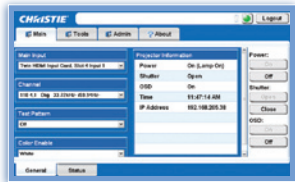

Main page controls and information.



Virtual On Screen Display (OSD): access full menu structure, remotely.



Status and diagnostics: displays alarm events for quick projector monitoring and diagnosis.



Admin screen includes upload, backup, restore and more.

[8] Automatic shut-off

This feature lowers the cost of ownership by reducing power consumption and extending lamp life when the projector is not in use. In this mode, if a signal is not detected, the projector will slowly dim the lamps then shut off one lamp, and finally if there is still no signal, the system will go into standby mode. If a signal is detected during the ramp-down phase the unit will revert back to its full power, dual lamp mode.

[8] Input cards



In total, there are four input card slots available. Each projector is equipped with a standard set of input cards.

Dual SD/HD – SDI input card



The Dual SD/HD-SDI input card accepts both standard-definition (SD) and high-definition (HD) serial-digital-interface (SDI) signals, and enables the user to connect

two of either types of signal. Both single-link HD and dual-link HD signals are accepted. This card also has two SD/HD-SDI outputs to enable “loop-through” for its respective input.

Analog input card

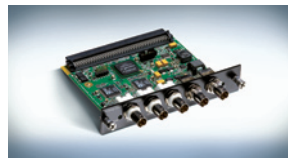

The Analog input card accepts an analog video signal input over a 5 BNC connector interface. It can accept RGBH&V signals over 5 connectors, as well

as component YPbPr signals on the RGB inputs.

Dual link DVI input card

The Dual link DVI input card has a 15-pin VGA connector for analog signals and a DVI-I connector which can support a single- or dual-link DVI HDCP video signal. The card can simultaneously support a digital signal on the DVI input and an analog signal on the VGA port.

DMX512 interface card



This interface card supports the DMX512 communication standard through two 5-pin XLR connectors.

Video decoder input card



The Video decoder input card accepts various types of standard definition (SD) video, including CVBS (composite video), S-video, and component. It accepts NTSC 3.58, NTSC 4.4,

PAL, PAL-N, PAL-M or SECAM formats. This card has two mini-DIN connectors (for S-video signals) and four BNC connectors that can be grouped to allow combinations of CVBS, S-Video, YPrPb or RGB video sources.

Twin HDMI™ input card



The Twin HDMI input card accepts two HDMI inputs and provides 12-bit deep color handling on the input. Additionally, advanced loop-through allows any

input on any input card to be looped through to the two HDMI outputs on the card.

LCD keypad



This easy-to-use LCD keypad includes:

- Contextual menus provide a fully-featured, intuitive interface; removing the need for a cluttered keypad

- Large, four line LCD display
- Adjustable brightness and timed LCD off mode
- Intuitive keypad design that lights up when features are active – making it user friendly
- Active keys are color-coded amber to indicate that selections will result in changes visible to the audience.

Dual-frequency receiver

The dual-frequency (38 kHz and 455 kHz) receiver ensure the projector receives signals at increased distances between the remote and projector, and reduces the affect of interference from lighting.

Quiet operation

When your presentation depends on the full attention of your audience you don't want them focused on the noise from your projector. The filter-free design with auto-sensing fan and temperature sensors automatically adjust for the quietest operation possible.

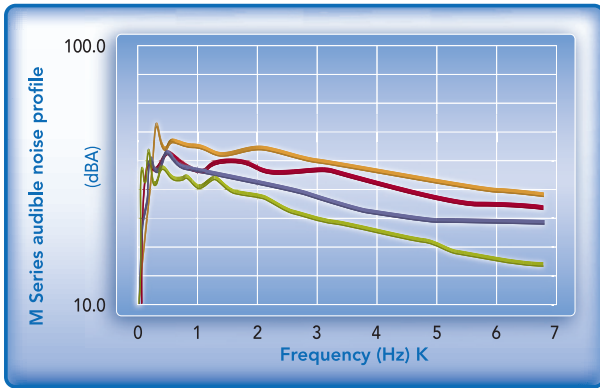

■ 200W single lamp mode ■ 350W dual lamp mode
 ■ 200W dual lamp mode ■ Max ambient with filter installed

Sound is reduced in the various modes, as well, high pitched, annoying frequencies are minimized.

Roadster models



The M Series Roadster models have been designed with staggers in mind. The Christie Roadster S+10K-M, Christie Roadster HD10K-M and Christie Roadster WU12K-M ship equipped with more input cards than the other M Series models, as well as a stacking frame.

Accessories

Whatever you need, Christie has a large selection of optional accessories. Create the projector you need by choosing from eight lenses, various input cards and much more.

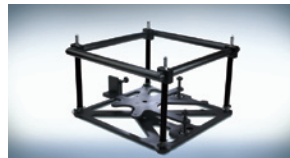

Optional stacking frame



Optional ceiling mount



Optional lamp



Optional lenses

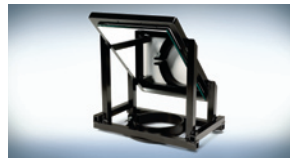

Optional portrait display adapter



Optional Christie AutoStack™

Filters (optional)

If the environment you're working in requires more than the protection of our dust sealed engine, choose from one of two filters (coarse dust and fog juice). Help extend the life of your projector and protect your investment from dirt, dust, sand as well as fog, smoke, hazers and pyrotechnics. Each M Series projector is equipped with two removable side panels that are designed to hold a filter, if required.

	Description	Part number
Lens - fixed	Lens ILS 0.73:1 SX+/0.67:1 HD	118-100110-XX
	Lens ILS 1.2:1 SX+ /1.1:1 HD	118-100117-XX
Lens - zoom	Lens ILS 1.25-1.6:1 SX+/1.16-1.49:1 HD	118-100111-XX
	Lens ILS 1.5-2.0:1 SX+/1.4-1.8:1 HD	118-100112-XX
	Lens ILS 2.0-2.8:1 SX+/1.8-2.6:1 HD	118-100113-XX
	Lens ILS 2.8-4.5:1 SX+/2.6-4.1:1 HD	118-100114-XX
	Lens ILS 4.5-7.5:1 SX+/4.1-6.9:1 HD	118-100115-XX
	Lens ILS 7.5-11.2:1 SX+/6.9-10.4:1 HD	118-100116-XX
Lamps*	Assembly 350W lamp	003-100857-XX
	Assembly 200W lamp	003-100856-XX
Input cards	Analog input	108-309101-XX
	Dual link DVI input	108-312101-XX
	Video decoder input	108-310101-XX
	Dual SD/HD-SDI input	108-313101-XX
	Twin HDMI input	108-311101-XX
	DMX512 interface	108-314101-XX
Miscellaneous accessories	Coarse dust filter pack M Series	118-100104-XX
	Fog juice filter pack M Series	118-100105-XX
	Stacking frame	118-100107-XX
	Ceiling mount	118-100108-XX
	Ceiling mount extension	104-101001
	Portrait display adapter	118-116109-XX
	ILS lens adapter kit	108-331108-XX
	Christie AutoStack™	108-308101-01

* Lamp power is specific to each model and cannot be interchanged.



Optional coarse dust filter

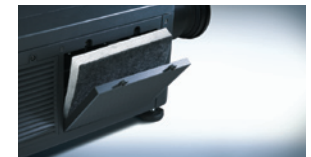

Optional fog juice filter

		Lens name												
		0.73:1 SX+/ 0.67:1 HD	1.2:1 SX+/ 1.1:1 HD	1.25-1.6:1 SX+/1.16-1.49:1 HD		1.5-2.0:1 SX+/ 1.4-1.8:1 HD		2.8-4.5:1 SX+/ 2.6-4.1:1 HD		7.5-11.2:1 SX+/6.9-10.4:1 HD				
		Lens throw ratio												
		0.73	1.2	1.25	1.6	1.5	2	2.8	4.5	7.5	11.2			
SX+ (4:3)	Screen size		Throw distance – ft (m)											
	Screen width – ft (m)	Screen height – ft (m)	4.8 (1.5)	3.6 (1.1)	3.5 (1.1)	5.8 (1.8)	6.0 (1.8)	7.7 (2.3)	7.2 (2.2)	9.6 (2.9)	13.4 (4.1)	21.6 (6.6)	36.0 (11.0)	53.8 (16.4)
			6.4 (2.0)	4.8 (1.5)	4.7 (1.4)	7.7 (2.3)	8.0 (2.4)	10.2 (3.1)	9.6 (2.9)	12.8 (3.9)	17.9 (5.5)	28.8 (8.8)	48.0 (14.6)	71.7 (21.8)
			12.8 (3.9)	9.6 (2.9)	9.3 (2.8)	15.4 (4.7)	16.0 (4.9)	20.5 (6.2)	19.2 (5.9)	25.6 (7.8)	35.8 (10.9)	57.6 (17.6)	96.0 (29.3)	143.4 (43.7)
			20.0 (6.1)	15.0 (4.6)	14.6 (4.5)	24.0 (7.3)	25.0 (7.6)	32.0 (9.8)	30.0 (9.1)	40.0 (12.2)	56.0 (17.1)	90.0 (27.4)	150.0 (45.7)	224.0 (68.3)
			24.0 (7.3)	18.0 (5.5)	17.5 (5.3)	28.8 (8.8)	30.0 (9.1)	38.4 (11.7)	36.0 (11.0)	48.0 (14.6)	67.2 (20.5)	108.0 (32.9)	180.0 (54.9)	268.8 (81.9)
			32.0 (9.8)	24.0 (7.3)	23.4 (7.1)	38.4 (11.7)	40.0 (12.2)	51.2 (15.6)	48.0 (14.6)	64.0 (19.5)	89.6 (27.3)	144.0 (43.9)	240.0 (73.2)	358.4 (109.2)
			40.0 (12.2)	30.0 (9.1)	29.2 (8.9)	48.0 (14.6)	50.0 (15.2)	64.0 (19.5)	60.0 (18.3)	80.0 (24.4)	112.0 (34.1)	180.0 (54.9)	300.0 (91.4)	448.0 (136.6)
WX (16:9)	Screen size		Throw distance – ft (m)											
	Screen width – ft (m)	Screen height – ft (m)	5.2 (1.6)	3.9 (0.9)	3.9 (1.2)	6.5 (2.0)	6.8 (2.1)	8.6 (2.6)	8.0 (2.5)	10.8 (3.3)	14.8 (4.5)	24.1 (7.4)	40.2 (12.3)	60.1 (18.3)
			7.0 (2.1)	3.9 (1.2)	5.2 (1.6)	8.6 (2.6)	9.0 (2.7)	11.5 (3.5)	10.7 (3.3)	14.4 (4.4)	19.8 (6.0)	32.2 (9.8)	53.6 (16.3)	80.1 (24.4)
			13.9 (4.3)	7.8 (2.4)	10.4 (3.2)	17.3 (5.3)	18.0 (5.5)	23.0 (7.0)	21.4 (6.5)	28.9 (8.8)	39.6 (12.1)	64.3 (19.6)	107.2 (32.7)	160.2 (48.8)
			21.8 (6.6)	12.3 (3.7)	16.3 (5.0)	27.0 (8.2)	28.1 (8.6)	36.0 (11.0)	33.5 (10.2)	45.1 (13.7)	61.9 (18.9)	100.5 (30.6)	167.5 (51.1)	250.4 (76.3)
			26.2 (8.0)	14.7 (4.5)	19.6 (6.0)	32.4 (9.9)	33.8 (10.3)	43.1 (13.2)	40.2 (12.3)	54.1 (16.5)	74.2 (22.6)	120.6 (36.8)	201.0 (61.3)	300.5 (91.6)
			34.9 (10.6)	19.6 (6.0)	26.1 (7.9)	43.2 (13.2)	45.0 (13.7)	57.5 (17.5)	53.6 (16.3)	72.2 (22.0)	99.0 (30.2)	160.8 (49.0)	268.0 (81.7)	400.6 (122.1)
			43.6 (13.3)	24.5 (7.5)	32.6 (9.9)	54.0 (16.5)	56.3 (17.2)	71.9 (21.9)	67.0 (20.4)	90.2 (27.5)	123.7 (37.7)	201.0 (61.3)	335.0 (102.1)	500.8 (152.6)
HD (16:9)	Screen size		Throw distance – ft (m)											
	Screen width – ft (m)	Screen height – ft (m)	5.2 (1.6)	2.9 (0.9)	3.5 (1.1)	5.8 (1.8)	6.1 (1.8)	7.8 (2.4)	7.3 (2.2)	9.4 (2.9)	13.6 (4.1)	21.4 (6.5)	36.1 (11.0)	54.4 (16.6)
			7.0 (2.1)	3.9 (1.2)	4.7 (1.4)	7.7 (2.3)	8.1 (2.5)	10.4 (3.2)	9.8 (3.0)	12.6 (3.8)	18.1 (5.5)	48.1 (14.7)	72.5 (22.1)	
			13.9 (4.3)	7.8 (2.4)	9.3 (2.8)	15.3 (4.7)	16.2 (4.9)	20.8 (6.3)	19.5 (6.0)	25.1 (7.7)	36.3 (11.1)	57.2 (17.4)	96.2 (29.3)	145.0 (44.2)
			21.8 (6.6)	12.3 (3.7)	14.6 (4.4)	24.0 (7.3)	25.3 (7.7)	32.5 (9.9)	30.5 (9.3)	39.2 (12.0)	56.7 (17.3)	89.3 (27.2)	150.3 (45.8)	226.6 (69.1)
			26.1 (8.0)	14.7 (4.5)	17.5 (5.3)	28.8 (8.8)	30.3 (9.2)	39.0 (11.9)	36.6 (11.2)	47.1 (14.3)	68.0 (20.7)	107.2 (32.7)	180.4 (55.0)	271.9 (82.9)
			34.9 (10.6)	19.6 (6.0)	23.4 (7.1)	38.3 (11.7)	40.4 (12.3)	51.9 (15.8)	48.8 (14.9)	62.8 (19.1)	90.6 (27.6)	142.9 (43.6)	240.6 (73.3)	362.6 (110.5)
			43.6 (13.3)	24.5 (7.5)	29.2 (8.9)	47.9 (14.6)	50.6 (15.4)	64.9 (19.8)	61.0 (18.6)	78.4 (23.9)	113.3 (34.5)	178.7 (54.5)	300.7 (91.7)	453.2 (138.1)
WU (16:10)	Screen size		Throw distance – ft (m)											
	Screen width – ft (m)	Screen height – ft (m)	5.1 (1.6)	3.2 (1.0)	3.4 (1.0)	5.6 (1.7)	5.9 (1.8)	7.6 (2.3)	7.1 (2.2)	9.2 (2.8)	13.2 (4.0)	20.9 (6.4)	35.1 (10.7)	52.9 (16.1)
			6.8 (2.1)	4.2 (1.3)	4.5 (1.4)	7.5 (2.3)	7.9 (2.4)	10.1 (3.1)	9.5 (2.9)	12.2 (3.7)	17.6 (5.4)	46.8 (14.3)	70.6 (21.5)	
			13.6 (4.1)	8.5 (2.6)	9.1 (2.8)	14.9 (4.5)	15.7 (4.8)	20.2 (6.2)	19.0 (5.8)	24.4 (7.4)	35.3 (10.8)	55.6 (17.0)	93.6 (28.5)	141.1 (43.0)
			21.2 (6.5)	13.2 (4.0)	14.2 (4.3)	23.3 (7.1)	24.6 (7.5)	31.6 (9.6)	29.7 (9.0)	38.2 (11.6)	55.1 (16.8)	86.9 (26.5)	146.3 (44.6)	220.5 (67.2)
			25.4 (7.8)	15.9 (4.8)	17.0 (5.2)	28.0 (8.5)	29.5 (9.0)	37.9 (11.6)	35.6 (10.9)	45.8 (14.0)	66.1 (20.2)	104.3 (31.8)	175.5 (53.5)	264.6 (80.6)
			33.9 (10.3)	21.2 (6.5)	22.7 (6.9)	37.3 (11.4)	39.3 (12.0)	50.5 (15.4)	47.5 (14.5)	61.1 (18.6)	88.2 (26.9)	139.1 (42.4)	234.0 (71.3)	352.8 (107.5)
			42.4 (12.9)	26.5 (8.1)	28.4 (8.7)	46.6 (14.2)	49.2 (15.0)	63.2 (19.3)	59.4 (18.1)	76.3 (23.3)	110.2 (33.6)	173.8 (53.0)	292.6 (89.2)	441.0 (134.4)

All values are within a 5% error.

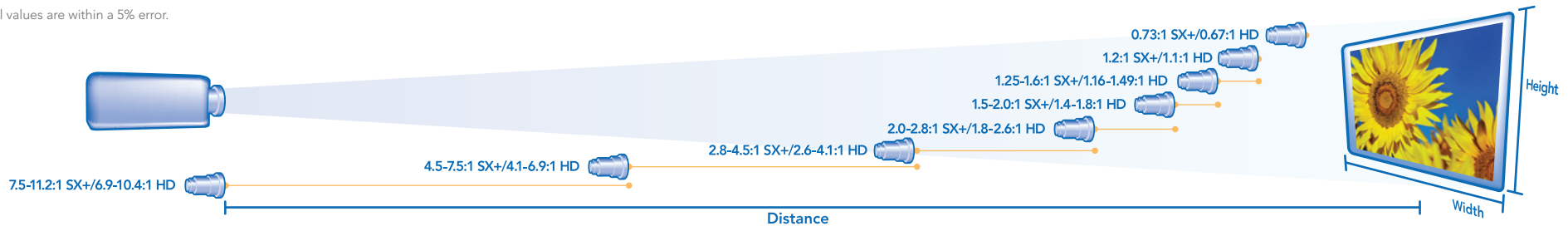

		SXGA+ (4:3)			HD (16:9)			WXGA (16:9)					
		DS+6K-M	DS+10K-M	Roadster S+10K-M	HD6K-M	HD10K-M	Roadster HD10K-M	WX7K-M	WX10K-M				
Image	brightness	dual lamp	6300 ANSI lumens (6930 center lumens)		10,500 ANSI lumens (11,550 center lumens)		6000 ANSI lumens (6600 center lumens)		10,000 ANSI lumens (11,000 center lumens)		5700 ANSI lumens (6270 center lumens)	9500 ANSI lumens (10,450 center lumens)	
		single lamp	3150 ANSI lumens (3465 center lumens)		5250 ANSI lumens (5775 center lumens)		3000 ANSI lumens (3300 center lumens)		5000 ANSI lumens (5500 center lumens)		2850 ANSI lumens (3135 center lumens)	4750 ANSI lumens (5225 center lumens)	
	contrast	2500-10,000:1 (full on/off) 650:1 ANSI (typical)											
	uniformity	90% brightness uniformity											
Display	type	3-chip 0.95" DMD						3-chip 0.85" DMD					
	native resolution	SX+ (1400 x 1050)			HD (1920 x 1080)			WXGA (1366 x 768)					
Lamp	type	Dual Osram 200W P-VIP		Dual Osram 350W P-VIP		Dual Osram 200W P-VIP		Dual Osram 350W P-VIP		Dual Osram 200W PVIP	Dual Osram 350W PVIP		
	life	high power	2000 hrs @ 200W		1500 hrs @ 350W		2000 hrs @ 200W		1500 hrs @ 350W		2000 hrs @ 200W	1500 hrs @ 350W	
		low power	3000 hrs @ 150W		2000 hrs @ 300W		3000 hrs @ 150W		2000 hrs @ 300W		3000 hrs @ 150W	2000 hrs @ 300W	
Input	standard	Analog BNC • Dual-link DVI		Analog BNC • Dual-link DVI • Dual SD/HD-SDI • Video decoder		Analog BNC • Dual-link DVI		Analog BNC • Dual-link DVI • Dual SD/HD-SDI • Video decoder		Dual-link DVI			
	optional	Analog • Dual-link DVI • Dual SD/HD-SDI • Video Decoder • Twin HDMI											
	signals	HDTV formats VGA through to QXGA (2048 x 1536) • Accepts all current HDTV/DTV formats • Multi-standard video decoder • Horizontal and vertical scaling, all inputs											
	pixel clock	165 MHz											
	scan rates	Horizontal: 15 to 120 kHz • Vertical: 23.97 to 150 Hz											
Inputs, control and networking		RS232 in/out • RS422 In • Ethernet (10/100) • USB Device • GPIO (RS232 9 Pin male connector) • Built-in backlit LCD keypad • Remote control (with optional wired XLR connection)											
Optical system		Dust sealed, 3-chip DMD light engine • Motorized horizontal and vertical lens offset • Scheimpflug (tilt) adjustment • Built-in light shutter • Tool-free lens insertion system											
Lenses	fixed	0.73:1 SX+/0.67:1 HD* • 1.2:1 SX+/1.1:1 HD											
	zoom	1.25-1.6:1 SX+/1.16-1.49:1 HD** • 1.5-2.0:1 SX+/1.4-1.8:1 HD • 2.0-2.8:1 SX+/1.8-2.6:1 HD • 2.8-4.5:1 SX+/2.6-4.1:1 HD • 4.5-7.5:1 SX+/4.1-6.9:1 HD • 7.5-11.2:1 SX+/6.9-10.4:1 HD											
	offsets ⁴	±100% Vertical • ±50% Horizontal • (* ±23%V / ±13%H) (** ±70%V ±45%H)			±120% Vertical • ±42% Horizontal • (* ±35%V / ±12%H) (** ±100%V ±40%H)			±150% Vertical • ±76% Horizontal (* ±50%V ±18%H) (** ±120%V ±58%H)					
Accessories	standard	User manual • IR remote • Line cord		Stacking frame • User manual • IR remote • Line cord		User manual • IR remote • Line cord		Stacking frame • User manual • IR remote • Line cord		User manual • IR remote • Line cord • HD15 to 5-wire BNC female adapter			
	optional	Coarse dust filter • Fog juice filter • Ceiling mount • Ceiling mount extension • ILS lens adapter kit • Portrait display adapter • Stacking frame • Christie AutoStack™											
Enhanced feature sets ³		LiteLOC™ • Comprehensive Color Adjustment (CCA™) • Embedded Christie Twist™ image warping and edge-blending • Intelligent Lens System (ILS™) for zoom, focus, horizontal and vertical offset for all lenses • Auto setup • Digital keystone correction • Dynamic iris • Menus in five languages • 99 channel memories • Multi-windowing and processing (up to a 3 x 3 array) • Motorized yellow notch filter (HD models only) • Black level blending ⁵											
Power requirements	operating voltage	110-240 VAC 50/60Hz											
	operating current	8.7 A @ 100 VAC		13.2 A @ 100 VAC		8.7 A @ 100 VAC		13.2 A @ 100 VAC		8.7 A @ 100 VAC		13.2 A @ 100 VAC	
	power	870W		1320W		870W		1320W		870W		1320W	
	dissipation	2971 BTU/hr		4508 BTU/hr		2971 BTU/hr		4508 BTU/hr		2971 BTU/hr		4508 BTU/hr	
Dimensions	size	(LxWxH): 22.1 x 19.7 x 10.2" (561 x 500 x 259mm)											
	shipping dimensions	(LxWxH): 29.0 x 27.0 x 24.6" (735 x 685 x 625mm)											
	weight	55lb (25kg) (without lens)											
	shipping weight	80lb (36kg)											
Operating environment		Temperature: 40 to 104° F (5 to 40° C) • Humidity: 20-80% non-condensing											
Regulatory approvals		UL/CSA/IEC 60,950 (3rd edition) • FCC Class A, CE, CCC • This product conforms to all relevant European directives, standards, safety, health and environmental concerns • RoHS, WEEE											
Limited warranty		3 years parts and labor (including light engine) • Contact an authorized Christie representative for full details of our limited warranty											

¹ US Patents 7,230,768; 6,205,271; 6,734,957. ² Patent pending. ³ Some features may not be functional on initial product shipments but will be enabled via software upgrade when available. ⁴ Values are for reference and should be validated with the Christie lens calculator. ⁵ Not available in WXGA models

WUXGA (16:10)		
WU7K-M	WU12K-M	Roadster WU12K-M
6300 ANSI lumens (6930 center lumens)	10,500 ANSI lumens (11,550 center lumens)	
3150 ANSI lumens (3465 center lumens)	5250 ANSI lumens (5775 center lumens)	

3-chip 0.96" DMD	
WUXGA (1920 x 1200)	
Dual Osram 200W PVIP	Dual Osram 350W PVIP
2000 hrs @ 200W	1500 hrs @ 350W
3000 hrs @ 150W	2000 hrs @ 300W

Analog BNC • Dual-link DVI	Analog BNC • Dual-link DVI • Dual SD/HD-SDI • Video decoder
----------------------------	---

±112% Vertical • ±54% Horizontal • (* ±22%V ±6%H) (** ±82%V ±38%H)

User manual • IR remote • Line cord	Stacking frame • User manual • IR remote • Line cord
-------------------------------------	---

8.7 A @ 100 VAC	13.2 A @ 100 VAC
870W	1320W
2971 BTU/hr	4508 BTU/hr

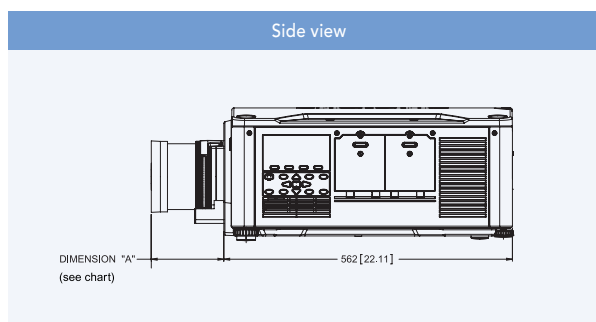
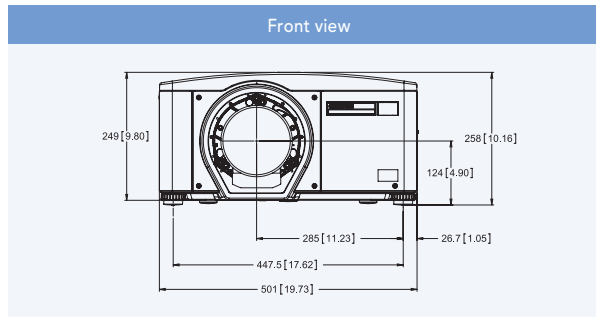

Description	Part number	Dimension 'A'
Lens ILS 0.73:1 SX+/0.67:1 HD	118-100110-XX	215mm (8.49")
Lens ILS 1.2SX+/1.1HD	118-100117-XX	279mm (11.01")
Lens ILS 1.25-1.6 SX+/1.16-1.49 HD	118-100111-XX	238mm (9.37")
Lens ILS 1.5-2.0 SX+/1.4-1.8 HD	118-100112-XX	205mm (8.07")
Lens ILS 2.0-2.8 SX+/1.8-2.6 HD	118-100113-XX	169mm (6.68")
Lens ILS 2.8-4.5 SX+/2.6-4.1 HD	118-100114-XX	155mm (6.14")
Lens ILS 4.5-7.5 SX+/4.1-6.9 HD	118-100115-XX	141mm (5.51")
Lens ILS 7.5-11.2 SX+/6.9-10.4 HD	118-100116-XX	199mm (7.86")

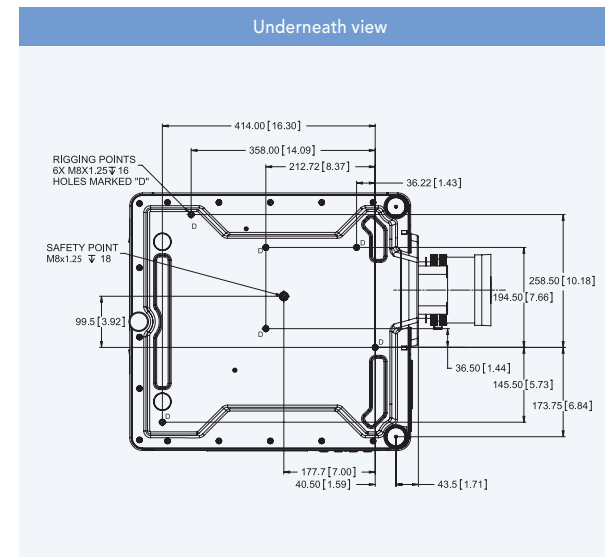
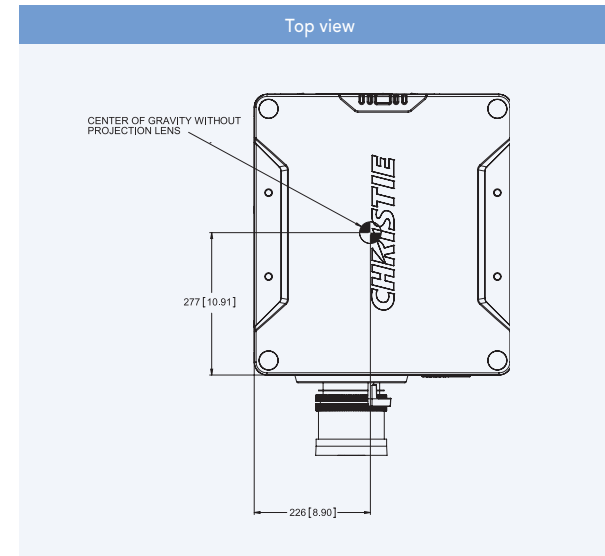

Corporate offices

Christie Digital Systems USA, Inc
USA – Cypress
ph: 714 236 8610

Christie Digital Systems Canada, Inc.
Canada – Kitchener
ph: 519 744 8005

Independent sales consultant offices

Spain
ph: +34 91 633 9990

Italy
ph: +39 (0) 2 9902 1161

South Africa
ph: +27 (0) 317 671 347

Worldwide offices

United Kingdom
ph: +44 (0) 118 977 8000

Germany
ph: +49 2161 664540

France
ph: +33 (0) 1 41 21 44 04

Eastern Europe and
Russian Federation
ph: +36 (0) 1 47 48 100

Dubai (United Arab Emirates)
ph: +971 (0) 4 299 7575

India
ph: (080) 41468941 – 48

Singapore
ph: +65 6877 8737

China (Shanghai)
ph: +86 21 6278 7708

China (Beijing)
ph: +86 10 6561 0240

Japan (Tokyo)
ph: 81 3 3599 7481

Korea (Seoul)
ph: +82 2 702 1601

ISO 9001



ISO 14001



For the most current specification information, please visit www.christiedigital.com



Copyright 2009 Christie Digital Systems USA, Inc. All rights reserved. All brand names and product names are trademarks, registered trademarks or tradenames of their respective holders. Canadian manufacturing facility is ISO 9001 and 14001 certified. Performance specifications are typical. Due to constant research, specifications are subject to change without notice. Printed in Canada on recycled paper. 2516 Sep 09